

SEAL:

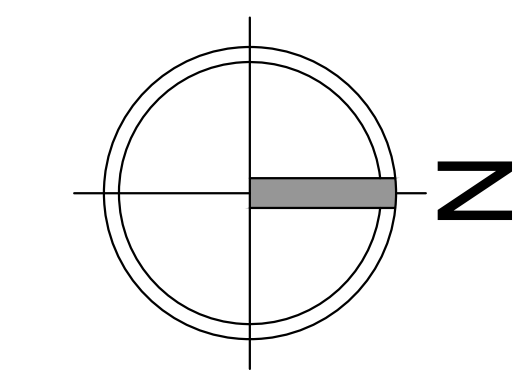

ACER CIRCINATUM 'PACIFIC FIRE'



CHAMAECYPARIS NOOTKATENSIS 'PENDULA'



CORNUS KOUS X NUTTALLI 'STARLIGHT'



HIBISCUS SYRIACUS



HYDRANGEA PANICULATA 'FIRELIGHT' ON STD



RHUS TYPHINA

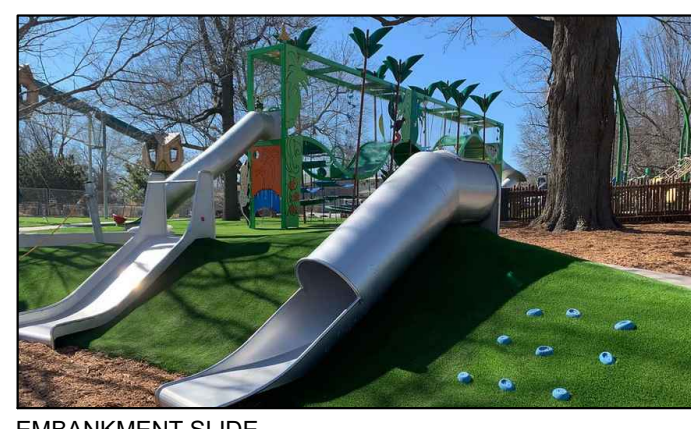

EMBANKMENT SLIDE



KOMPAN JUNIOR SPICA

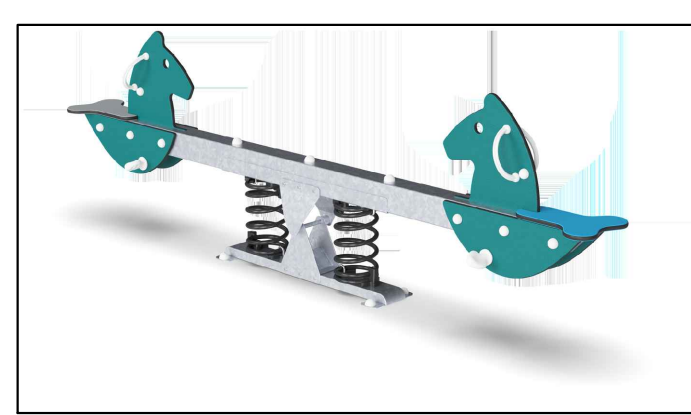

KOMPAN HORSE SEESAW



MODULAR ALUMINUM PLANTERS



GREEN THEORY DEK BENCHES

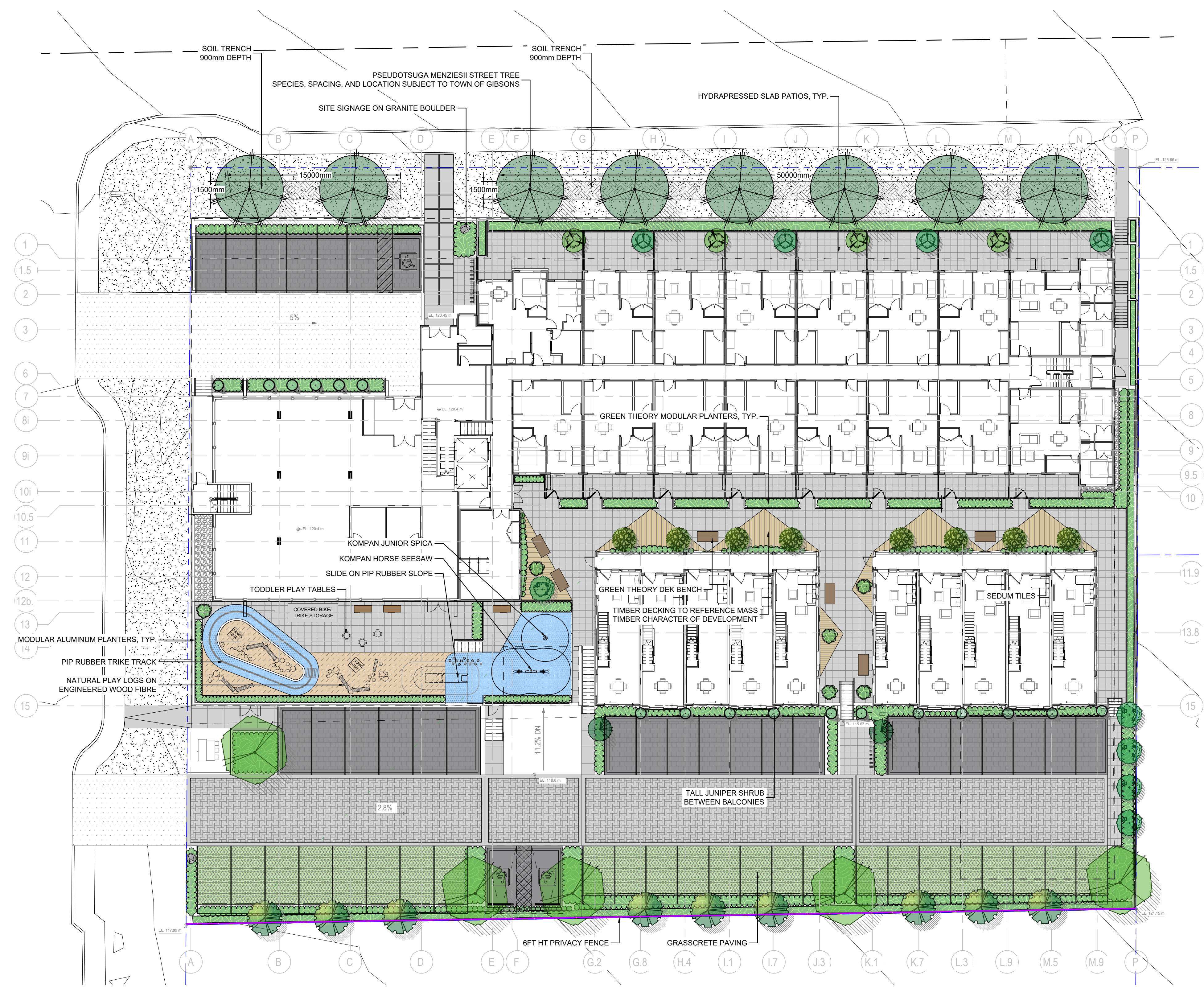

FURNISHINGS LEGEND

- KOMPAN ELE400158 JUNIOR SPICA
- KOMPAN M182 HORSE SEESAW
- EMBANKMENT SLIDE
- NATURAL PLAY LOGS
- GREEN THEORY DEK BENCH

MATERIALS LEGEND

- IRRIGATED SHRUB PLANTING
- 18x18 HYDRAPRESSED SLAB
- BROOM FINISHED SIDEWALK
- VEHICLE RATED PERMEABLE PAVERS, NATURAL
- PERMEABLE PAVEMENT PARKING STALLS CHARCOAL
- GRASSCRETE PAVING
- TIMBER DECKING
- COLOURED RUBBER P.I.P. PLAY SURFACE
- ENGINEERED WOOD FIBRE PLAY SURFACE

TREE SCHEDULE

KEY	QTY	BOTANICAL NAME	COMMON NAME	PLANTED SIZE / REMARKS
	5	ACER CIRCINATUM 'PACIFIC FIRE'	PACIFIC FIRE VINE MAPLE	2.5M HT, B&B; 3 STEM CLUMP
	9	CARPINUS BETULUS 'FRANS FONTAINE'	COLUMNAR EUROPEAN HORNBEAM	5CM CAL; 1.8M STD; B&B; DROUGHT TOLERANT
	2	CHAMAECYPARIS NOOTKATENSIS 'PENDULA'	WEeping NOOTKA CYPRESS	2M HT, B&B
	5	CORNUS KOUSA X NUTTALLI 'STARLIGHT'	STARLIGHT HYBRID DOGWOOD	2.5M HT, B&B
	4	HIBISCUS SYRIACUS	ROSE OF SHARON	1.2M STD
	4	HYDRANGEA PANICULATA 'FIRELIGHT'	FIRELIGHT HYDRANGEA; PINK	1.2M STD
	8	RHUS TYPHINA 'TIGER EYES'	TIGER EYES STAGHORN SUMAC	#7 POT

NOTES: * PLANT SIZES IN THIS LIST ARE SPECIFIED ACCORDING TO THE BC LANDSCAPE STANDARD AND CANADIAN LANDSCAPE STANDARD, LATEST EDITION. CONTAINER SIZES SPECIFIED AS PER ONLA STANDARD. BOTH PLANT SIZE AND CONTAINER SIZE ARE THE MINIMUM ACCEPTABLE SIZES. * REFER TO SPECIFICATIONS FOR DEFINED CONTAINER MEASUREMENTS AND OTHER PLANT MATERIAL REQUIREMENTS. * SEARCH AND REVIEW: MAKE PLANT MATERIAL AVAILABLE FOR OPTIONAL REVIEW BY LANDSCAPE ARCHITECT AT SOURCE OF SUPPLY. AREA OF SEARCH TO INCLUDE LOWER MAINLAND AND FRASER VALLEY. * SUBSTITUTIONS: OBTAIN WRITTEN APPROVAL FROM THE LANDSCAPE ARCHITECT PRIOR TO MAKING ANY SUBSTITUTIONS TO THE SPECIFIED MATERIAL. UNAPPROVED SUBSTITUTIONS WILL BE REJECTED. ALLOW A MINIMUM OF FIVE DAYS PRIOR TO DELIVERY FOR REQUEST TO SUBSTITUTE. SUBSTITUTIONS ARE SUBJECT TO BC LANDSCAPE STANDARD AND CANADIAN LANDSCAPE STANDARD - DEFINITION OF CONDITIONS OF AVAILABILITY. * ALL LANDSCAPE MATERIAL AND WORKMANSHIP MUST MEET OR EXCEED BC LANDSCAPE STANDARD AND CANADIAN LANDSCAPE STANDARD LATEST EDITION. * ALL PLANT MATERIAL MUST BE PROVIDED FROM CERTIFIED DISEASE FREE NURSERY. * BIO-SOLIDS NOT PERMITTED IN GROWING MEDIUM UNLESS AUTHORIZED BY LANDSCAPE ARCHITECT.



NO.	DATE	REVISION DESCRIPTION	DR.
2	24.APR.08	NEW SITE PLAN	SA
1	24.MAR.13	CONCEPT FOR ADP	SA

CLIENT:

PROJECT:

MIXED USE PROJECT
718 NORTH ROAD
GIBSONS

DRAWING TITLE:

DATE:

DRAWING NUMBER:

SCALE:

DRAWN:

DESIGN:



CHK'D:

OF 3

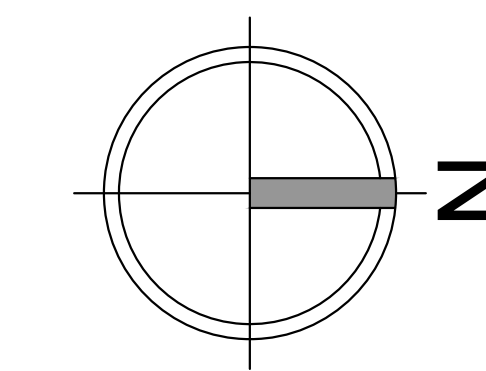
SEAL:



MATERIALS LEGEND

-  IRRIGATED SHRUB PLANTING
-  18x18 HYDRAPRESSED SLAB



1
1.5
2
3
4
5
8
9
9.5
10

NO.	DATE	REVISION DESCRIPTION	DR.
2	24.APR.08	NEW SITE PLAN	SA
1	24.MAR.13	CONCEPT FOR ADP	SA

CLIENT:

PROJECT:

MIXED USE PROJECT

**718 NORTH ROAD
GIBSONS**

DRAWING TITLE:

DATE:

DRAWING NUMBER:

SCALE:

DRAWN:

DESIGN:

CHK'D:

SEAL:

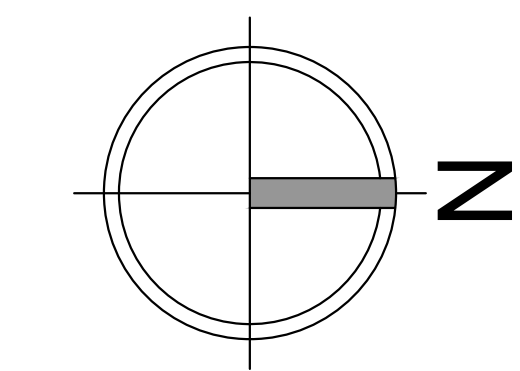

2	24.APR.08	NEW SITE PLAN	SA
1	24.MAR.13	CONCEPT FOR ADP	SA
NO.	DATE	REVISION DESCRIPTION	DR.

CLIENT:

PROJECT:

MIXED USE PROJECT

**718 NORTH ROAD
GIBSONS**

DRAWING TITLE:

DATE:

DRAWING NUMBER:

SCALE:

DRAWN:

DESIGN:

CHK'D:

OF 3

PMG PROJECT NUMBER:

24-012

24012-2.ZIP

ROOF TREE SCHEDULE

PMG PROJECT NUMBER: 24-012

KEY	QTY	BOTANICAL NAME	COMMON NAME	PLANTED SIZE / REMARKS
	2	OLEA EUROPEA 'UNIVERSAL'	OLIVE	#7 POT
	5	RHUS TYPHINA 'TIGER EYES'	TIGER EYES STAGHORN SUMAC	#7 POT

NOTES: * PLANT SIZES IN THIS LIST ARE SPECIFIED ACCORDING TO THE BC LANDSCAPE STANDARD AND CANADIAN LANDSCAPE STANDARD, LATEST EDITION. CONTAINER SIZES SPECIFIED AS PER CNLA STANDARD. BOTH PLANT SIZE AND CONTAINER SIZE ARE THE MINIMUM ACCEPTABLE SIZES. * REFER TO SPECIFICATIONS FOR DEFINED CONTAINER MEASUREMENTS AND OTHER PLANT MATERIAL REQUIREMENTS. * SEARCH AND REVIEW: MAKE PLANT MATERIAL AVAILABLE FOR OPTIONAL REVIEW BY LANDSCAPE ARCHITECT AT SOURCE OF SUPPLY. AREA OF SEARCH TO INCLUDE LOWER MAINLAND AND FRASER VALLEY. * SUBSTITUTIONS: OBTAIN WRITTEN APPROVAL FROM THE LANDSCAPE ARCHITECT PRIOR TO MAKING ANY SUBSTITUTIONS TO THE SPECIFIED MATERIAL. UNAPPROVED SUBSTITUTIONS WILL BE REJECTED. ALLOW A MINIMUM OF FIVE DAYS PRIOR TO DELIVERY FOR REQUEST TO SUBSTITUTE. SUBSTITUTIONS ARE SUBJECT TO BC LANDSCAPE STANDARD AND CANADIAN LANDSCAPE STANDARD - DEFINITION OF CONDITIONS OF AVAILABILITY. * ALL LANDSCAPE MATERIAL AND WORKMANSHIP MUST MEET OR EXCEED BC LANDSCAPE STANDARD AND CANADIAN LANDSCAPE STANDARD LATEST EDITION. * ALL PLANT MATERIAL MUST BE PROVIDED FROM CERTIFIED DISEASE FREE NURSERY. * BIO-SOLIDS NOT PERMITTED IN GROWING MEDIUM UNLESS AUTHORIZED BY LANDSCAPE ARCHITECT.

MATERIALS LEGEND

- IRRIGATED SHRUB PLANTING
- 18x18 HYDRAPRESSED SLAB
- TIMBER DECKING

FURNISHINGS LEGEND

- LIFESPACE SELF-WATERING PLANTER
- LIFESPACE HARVEST TABLE
- CATENARY LIGHTING
- MOVEABLE CAFE STYLE CHAIRS AND TABLES
- GREEN THEORY DEK PLATFORM BENCH

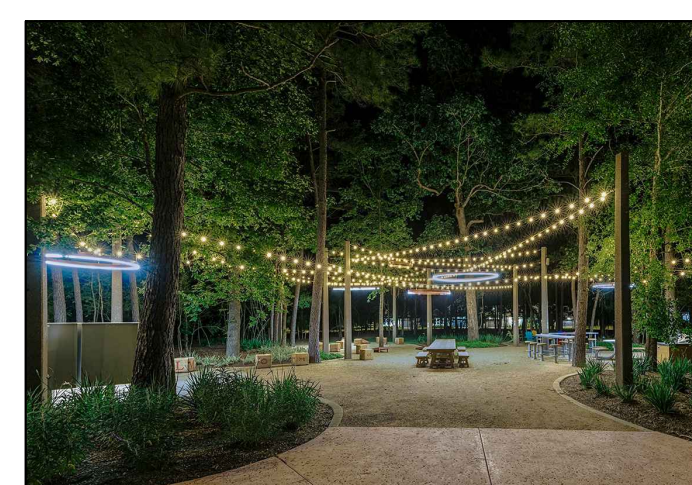

CATENARY LIGHTING



CAFE STYLE CHAIRS AND TABLES



COMMUNITY GARDEN



HARVEST TABLE

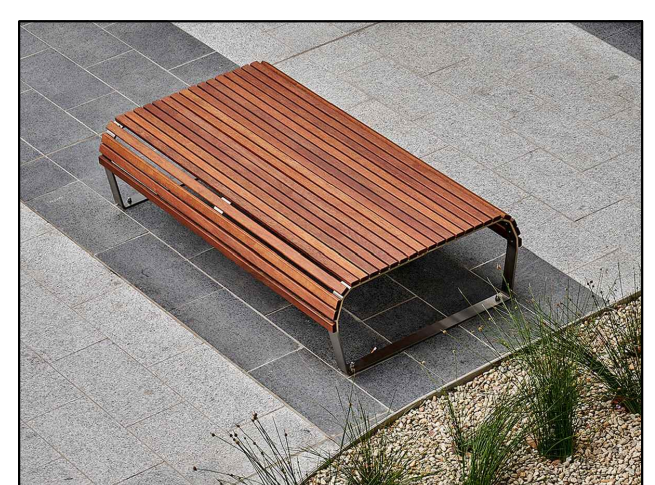

GREEN THEORY DEK PLATFORM BENCH

24012-2.ZIP